

■ Contents

Safety	2
Warnings	2
Symbols used in this manual	2
Operator's safety	2
Avoid filter module damage	2
DC-link resonance	2
Description	3
Description	3
Ordering numbers, 380 - 415 V	4
Ordering numbers, 440 - 480 V	5
Calculation of the filter size needed	5
Specifications	6
General technical data	6
Environmental data	6
Dimensions/weight	7
Dimension diagrams	8
Installation	10
Mechanical installation	10
Ventilation	10
Power wiring	10
Over temperature contactor	11
Power wiring size (copper)	11
Operation on different mains type	12
Typical installation in a panel or other enclosures	12
Commissioning	14
Commissioning	14
Appendix: Safety and application notes for	15
1. General	15
2. Application as directed	15
3. Transport, Storage	15
4. Installation	15
5. Electrical Installation	15
6. Operation	15
7. Maintenance and service	16

■ Warnings



The Danfoss harmonic filter AHF 005 and AHF 010 contain dangerous voltages when connected to line voltages. Only a competent electrician should carry out the electrical installation. Improper installation of the filter module or the connected frequency converter may cause equipment failure, serious injury or death. Follow this manual and National Electrical Codes and local safety codes.
Operation of the harmonic filter is only allowed with a closed cover of the housing!

■ Symbols used in this manual

When you read this manual you will come across different symbols that require special attention. The symbols used are the following:



Warning of hazardous electrical voltage



Warning of a general danger



NB!:

This note designates general, useful notes. If you observe it, handling of the filter module / drive system is made easier.

■ Operator's safety



After mains disconnections, the power terminals X1.1, X1.2 and X1.3 remain live for minimum 15 minutes.



The filter modules have to be installed in a way, that they fulfil their function and don't expose persons to danger. They have to be mounted correctly and used in accordance with their purpose.

■ Avoid filter module damage

1. The filter modules are to be used only with Danfoss frequency converters. The usage with other electrical loads is not permitted and may damage the devices.
2. Don't use the drive system (frequency converter, motor load and filter module) if the equipment has been damaged.
3. Modifications of the filter modules are not allowed.

■ DC-link resonance

To prevent resonance's in the DC-link, it is recommended to disable the dynamic DC link compensation.

483 Dynamic DC link compensation (DC LINK COMP.)

Value:

Off	[0]
★On	[1]

Function:

The VLT 5000, 6000 and 8000 series include a feature, which ensures that the output voltage is independent of any voltage fluctuation in the DC link, e.g. caused by fast fluctuation in the mains supply voltage. The benefit is a very steady torque on motor shaft (low torque ripple) under most mains conditions.

Description of choice:

In some cases this very dynamic compensation can cause resonance's in the DC link and should then be disabled. Typical cases are where a line choke or a passive harmonic filter (e.g. filters AHF005/010) is mounted in the mains supply to the frequency converter to suppress harmonics. Can also occur on mains with low short circuit ratio.

■ Description

The Danfoss harmonic filters AHF 005 and AHF 010 are ensuring near sinusoidal line current minimising the harmonic current emission into the mains supply. The Danfoss AHF 005 and AHF 010 are advanced harmonic filters not to be compared with traditional harmonic trap filters. The Danfoss harmonic filters have been specially designed to match all the Danfoss frequency converters. The filters AHF 010 and AHF 005 are available in two voltage ratings.

- 380 - 415 V AC
- 440 - 480 V AC

The Danfoss AHF 010 and AHF 005 have the following characteristics:

- Small compact housing that fits into a panel
- Easy to use in retrofit applications
- AHF 010 reduces the total harmonic current distortion to 10%*
- AHF 005 reduces the total harmonic current distortion to 5%*
- Current rating from 10A - 325A
- For higher power modules can be paralleled
- One filter module can be used for several frequency converters
- High efficiency (> 0.98)
- User-friendly commissioning - no adjustment necessary

- No routine maintenance required

* THiD of 10% or 5% will be achieved when the following conditions are met:

- THvD of the system without the drive operating is less than 2%
- Filter is operating at nominal load

If these conditions are not fulfilled, a significant reduction of the harmonic components can still be achieved, but the rated THiD values may not be achieved.

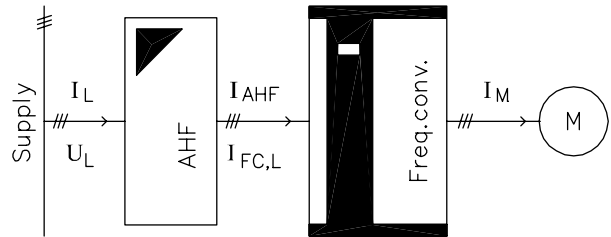

Principle connection diagram of the Danfoss harmonic filter.

Legends (as used throughout this manual):

I_L :	Line current
U_L :	Line voltage
I_{AHF} :	Output current of the filter AHF
$I_{FC,L}$:	Input current to the frequency converter
I_M :	Motor current

■ Ordering numbers, 380 - 415 V
AHF 005 and AHF 010, 380V - 415V, 50Hz

I _{AHF,N}	Danfoss ordering number		Typical Danfoss frequency converter*		
	AHF 005	AHF 010	VLT 5000 series	VLT 6000 series	VLT 8000 series
10 A	175G6600	175G6622	5006, 5008	6006, 6008	8006, 8008
19 A	175G6601	175G6623	5011, 5016	6011, 6016	8011, 8016
26 A	175G6602	175G6624	5022	6022	8022
35 A	175G6603	175G6625	5027	6027	8027
43 A	175G6604	175G6626	5032	6032	8032
72 A	175G6605	175G6627	5042, 5052	6042, 6052	8042, 8052
101 A	175G6606	175G6628	5062, 5072	6062, 6072	8062, 8072
144 A	175G6607	175G6629	5100	6100, 6102	8100, 8102
180 A	175G6608	175G6630	5125	6125	8125
217 A	175G6609	175G6631	5150	6150	8150
289 A	175G6610	175G6632	5200, 5250	6175, 6225	8200, 8250
324 A	175G6611	175G6633			

Higher ratings can be achieved by paralleling the filter units

397 A	180A and 217A unit	5300	6275	8300
469 A	180A and 289A unit	5350	6350	8350
578 A	Two 289A units	5450	6400	8450
648 A	Two 324A units	5500	6500, 6560	8500

* Please note that the matching of the typical Danfoss frequency converter and filter is pre-calculated based on 400V and assuming typical motor load. VLT 5000 series is based on a 160 % torque application, while VLT 6000 and 8000 series are based on 110% torque application. The pre-calculated filter current may be varying from the input current ratings of VLT 5000, VLT 6000 and VLT 8000 series as stated in the respective operating instructions, as these numbers are based on different operating conditions.

■ Ordering numbers, 440 - 480 V

AHF 005 and AHF 010, 440V - 480V, 60Hz

I _{AHF,N}	Danfoss ordering number		Typical Danfoss frequency converter*		
	AHF 005	AHF 010	VLT 5000 series	VLT 6000 series	VLT 8000 series
19 A	175G6612	175G6634	5011, 5016	6011, 6016	8011, 8016
26 A	175G6613	175G6635	5022	6022	8022
35 A	175G6614	175G6636	5027, 5032	6027, 6032	8027
43 A	175G6615	175G6637	5042	6042	8032
72 A	175G6616	175G6638	5052, 5062	6052, 6062	8042, 8052
101 A	175G6617	175G6639	5062	6072	8062, 8072
144 A	175G6618	175G6640	5075, 5072	6100, 6125, 6102	8100, 8125, 8102
180 A	175G6619	175G6641	5125	6150	8150
217 A	175G6620	175G6642	5150	6175	8200
289 A	175G6621	175G6643	5200, 5250	6225	8250

Higher ratings can be achieved by paralleling the filter units

360 A	Two 180A units	5300	6275	8300
434 A	Two 217A units	5350	6350	8350
506 A	217A and 289A units		6400	8450
578 A	Two 289A units	5450, 5500	6500	8500

Description

* Please note that the matching of the typical Danfoss frequency converter and filter is pre-calculated based on 480V and assuming typical motor load. VLT 5000 series is based on a 160 % torque application, while VLT 6000 and 8000 series are based on 110% torque application. The pre-calculated filter current may be varying from the input current ratings of VLT 5000, VLT 6000 and VLT 8000 series as stated in the respective operating instructions, as these numbers are based on different operating conditions.

■ Calculation of the filter size needed

For optimal performance the harmonic filter must be sized for the line input current to the frequency converter, i.e. the input current drawn based on the expected load of the frequency converter and not the size of the frequency converter itself!

The line input current to the frequency converter (I_{FC,L}) can be calculated using the nominal motor current (I_{M,N}) and displacement power factor (Cos φ) of the motor. Both data are normally printed on the nameplate of the motor. In the case where the nominal motor voltage (U_{M,N}) is unequal to the actual line-line voltage (U_L) the calculated current

must be corrected with the ratio between these voltages as shown in the equation below.

$$I_{FC,L} = 1.16 * I_{M,N} * \cos(\varphi) * ((U_{M,N}) / (U_L))$$

The harmonic filter chosen must have a nominal current (I_{AHF,N}) equal to or larger than the calculated frequency converter line input current (I_{FC,L}). If several frequency converters are to be connected to the same filter the harmonic filter must be sized according to the sum of the calculated line currents.



If the harmonic filter is sized for the load, and the motor of the corresponding frequency converter is changed, the current must be re-calculated to avoid overload of the harmonic filter.

■ General technical data

		AHF 0xx	AHF 0xx
Nominal supply voltage	$U_{L,N}$ [V]	$380 \leq U_{L,N} \leq 415$	$440 \leq U_{L,N} \leq 480$
Tolerance of the actual supply voltage	U_L [V]	$342 \leq U_L \leq 456$	$396 \leq U_L \leq 528$
Supply frequency	$f_{i,N}$ [Hz]	$50 \pm 5 \%$	$60 \pm 5 \%$
Overload capability		1,6 for 60s	
Efficiency	η [%]	~ 98,5 %	
THiD	[%]	AHF 005 < 5% AHF 010 < 10%	
$\cos \phi$ of I_L		0.85 cap 0.99 cap 1.00	at 75% $I_{AHF,N}$ at 100% $I_{AHF,N}$ at 150% $I_{AHF,N}$
Power derating	[%/K] [%/m]	$40^\circ\text{C} < T_a < 55^\circ\text{C} \Rightarrow 3\%/K$ $1000\text{m a.m.s.l.} < h \leq 4000\text{m a.m.s.l.} \Rightarrow 5\%/1000\text{m}$	

NB!:

The reduction of the low harmonic current emission to the rated THiD implies, that the THvD of the non-influenced mains voltage is lower than 2% and the ratio of short circuit power to installed load (R_{SCE}) is at least 66. Under these conditions the THiD of the mains current of the frequency converter is reduced to 10% or 5% (typical values at nominal load). If these conditions are not or only partially fulfilled, a significant reduction of the harmonic components can still be achieved, but the rated THiD values may not be achieved.

■ Environmental data

Permissible temperature range*	During transport of the unit: $-25^\circ\text{C} \dots +70^\circ\text{C}$ (to VDE 0160) During storage of the unit: $-25^\circ\text{C} \dots +55^\circ\text{C}$ (to VDE 0160) During operation of the unit: $5^\circ\text{C} \dots +40^\circ\text{C}$ without power derating $40^\circ\text{C} \dots +55^\circ\text{C}$ with power derating
Humidity class*	Humidity class F without condensation (5% - 85% relative humidity)
Installation height h^*	$H \leq 1000$ m a.m.s.l. without power derating 1000 m a.m.s.l. < $h \leq 4000$ m a.m.s.l. with power derating
Degree of pollution	VDE 0110 Part 2 degree 2
Insulation strength	Overvoltage category III according to VDE 0110
Packaging	DIN 55468 for transport packaging materials
Type of protection	IP 20
Approvals	CE: Low-Voltage Directive

*climatic conditions according to class 3K3
(EN 50178 Part 6.1)

■ Dimensions/weight

The AHF-modules are available in seven frame sizes (size A to G).

For dimensions see the drawings on the following pages

AHF 010, 380 – 415 V AC, 50Hz			AHF 010, 440 – 480 V AC, 60Hz		
I _{AHF,N}	Frame size	Weight	I _{AHF,N}	Frame size	Weight
10 A	B	19 Kg			
19 A	B	21 Kg	19 A	B	23 Kg
26 A	B	22 Kg	26 A	B	34 Kg
35 A	B	31 Kg	35 A	B	40 Kg
43 A	C	38 Kg	43 A	C	45 Kg
72 A	D	56 Kg	72 A	D	61 Kg
101 A	D	69 Kg	101 A	D	75 Kg
144 A	D	97 Kg	144 A	E	95 Kg
180 A	E	103 Kg	180 A	E	107 Kg
217 A	E	112 Kg	217 A	F	119 Kg
289 A	F	135 Kg	289 A	F	145 Kg
324 A	F	180 Kg			

AHF 005, 380 – 415 V AC, 50Hz			AHF 005, 440 – 480 V AC, 60Hz		
I _{AHF,N}	Frame size	Weight	I _{AHF,N}	Frame size	Weight
10 A	B	21			
19 A	B	25	19 A	B	29
26 A	C	28	26 A	C	40
35 A	C	39	35 A	C	50
43 A	D	50	43 A	D	52
72 A	D	74	72 A	D	89
101 A	E	82	101 A	E	150
144 A	E	130	144 A	E	169
180 A	F	144	180 A	F	178
217 A	F	162	217 A	F	225
289 A	G	201	289 A	G	273
324 A	G	255			

■ Dimension diagrams Frame size A

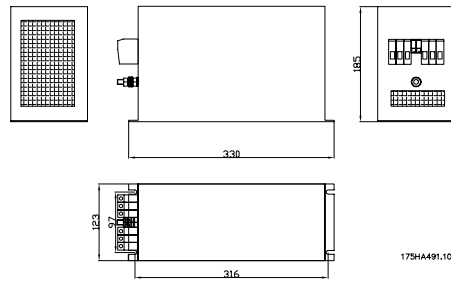

Frame size B

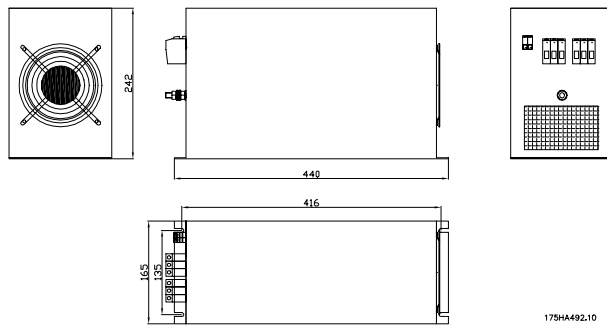

Frame size C

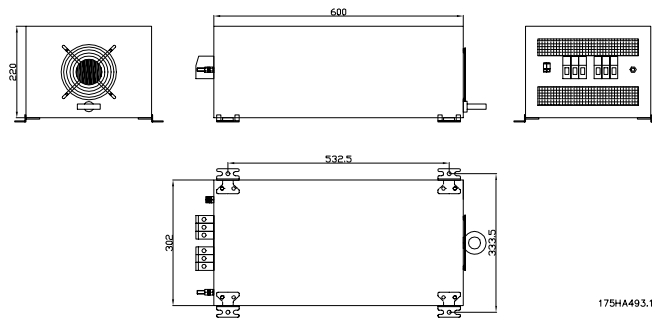

Frame size D



Frame size E

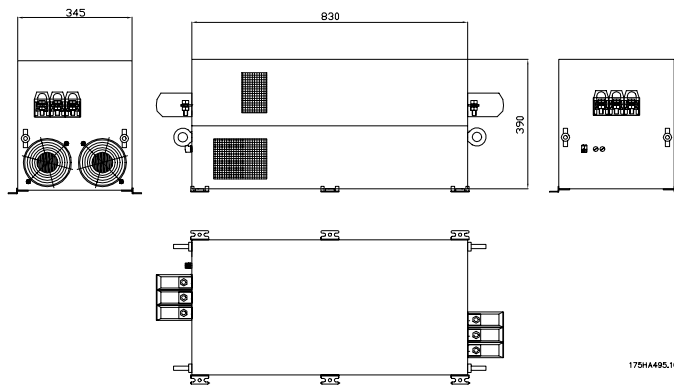

Frame size F

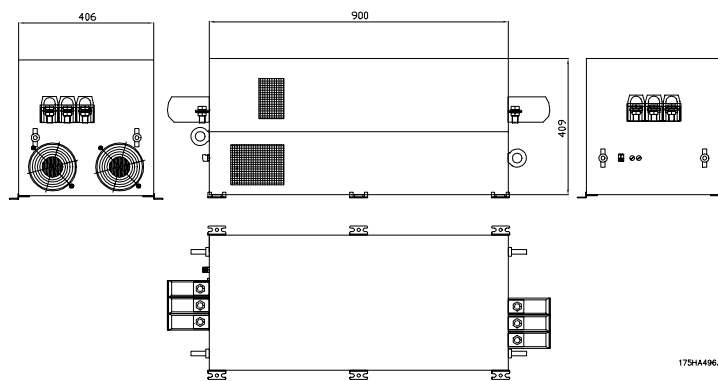

Frame size G

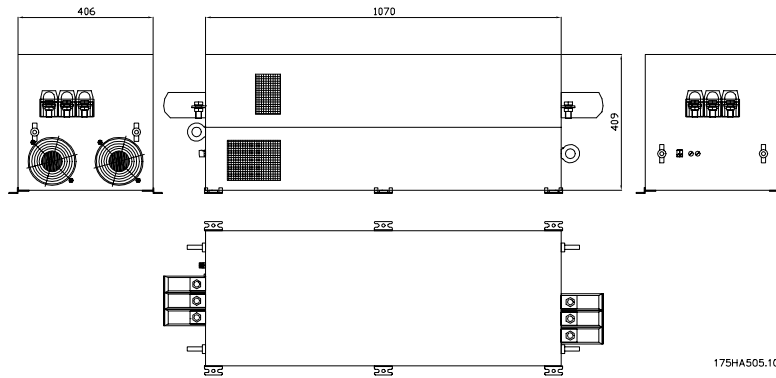

■ Mechanical installation

The encapsulation of the filters have an IP 20 rating. The modules can be mounted side by side with 60mm clearance.

To other components and to the cabinet walls keep a horizontal clearance of at least 70mm and a vertical clearance of at least 150mm.



For versions with bus bars (frame size E – G) it is necessary to mount the added covers to the connectors in order to achieve the protection type IP 20.

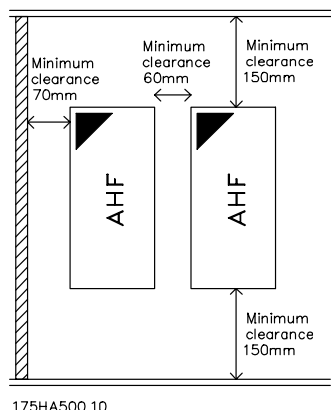

■ Ventilation

The filters are cooled by means of air circulation. Consequently, the air needs to be able to move freely above and below the filter module. The efficiency

of the filter modules is greater than 0.98. When installing a filter module in a panel or another enclosure, ensure there is sufficient airflow through the enclosure to limit heat rise in the enclosure.

AHF 0xx 380 – 415V	Max. Heat	AHF 0xx 440 – 480V	Max. Heat
10 A	108 W	19 A	236 W
19 A	205 W	26 A	324 W
26 A	280 W	35 A	436 W
35 A	377 W	43 A	536 W
43 A	463 W	72 A	898 W
72 A	776 W	101 A	1260 W
101 A	1089 W	144 A	1796 W
144 A	1553 W	180 A	2245 W
180 A	1941 W	217 A	2706 W
217 A	2340 W	289 A	3604 W
289 A	3116 W		
324 A	3493 W		



NB!:

If other heat sources (e.g. Danfoss frequency converters) are installed in an enclosure with the harmonic filter AHF 0xx, this heat generation must also be considered when calculating required airflow



NB!:

If the cooling air is polluted (dust, dirt swirl, grease, aggressive gas) the function of the filter module may be impeded. Ensure sufficient countermeasures, e.g. separate cooling air, mounting of air filters, periodical cleaning.

■ Power wiring

Standard connection

Supply voltage must be connected to the terminals X1.1, X1.2 and X1.3. The frequency converter supply terminals L1, L2 and L3 must be connected to the filter module terminals X2.1, X2.2 and X2.3.

Paralleling of FC's

If several frequency converters are to be connected to one harmonic filter the connection is similar to the standard connection - The supply terminals L1, L2 and L3 of several frequency converters must be connected to the filter module terminals X2.1, X2.2 and X2.3.



NB!:

If several FC's are to be connected to the same filter the harmonic filter must be sized according to the sum of the calculated input current to the FC's.

Paralleling of filters

If the line input current of the frequency converter exceeds the nominal current of the largest harmonic filter, several harmonic filters can be paralleled to achieve the necessary rating. Supply voltage must be connected to the terminals X1.1, X1.2 and X1.3 of the filters. The frequency converter supply terminals L1, L2 and L3 must be connected to the filter modules terminals X2.1, X2.2 and X2.3.



NB!:

Filters of different current ratings can be paralleled. The rating of the filter becomes the sum of the individual current ratings.



Use cables complying with local regulations.

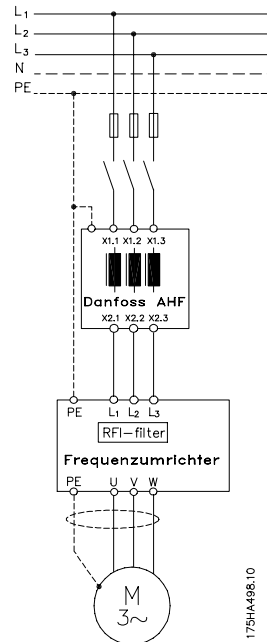

Over temperature contactor

The Danfoss harmonic filter AHF 005 and AHF 010 is equipped with a galvanic isolated contactor that is closed under normal operating conditions and open if the filter is overheated. This contactor can be used for preventing damaging of the filter caused by over temperature as shown in the following example.

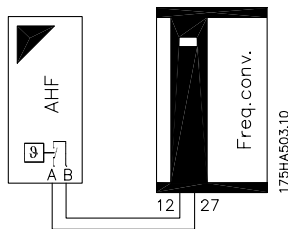

Example: Connect terminal A of the harmonic filter to terminal 12 or 13 (voltage supply digital input, 24V) of the Danfoss frequency converter and terminal B to terminal 27 (digital input "Coast Inverse") the frequency converter will let go of the motor (coasting) and thereby unload the filter if a over temperature is detected.



NB!:

The maximum rating of the over temperature contactor is 250V AC and 10A.

Power wiring size (copper)

Enclosure	Max. cable size [mm ²]	Type
A	16	Connector
B	16	Connector
C	50	Connector
D	50	Connector
E	*	Bus Bars
F	*	Bus Bars
G	*	Bus Bars
Overheat Contactor	4	Connector

*Power wiring used for connection of the filter AHF 005 and AHF 010 in enclosure size E, F and G must be terminated with cable lugs that can be attached to the input and output bus bars terminals. This

type of termination imposes no specifications of the minimum and maximum cable size suitable for connection. Power terminal details regarding the bus bars can be found in the figures below.

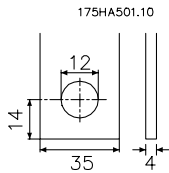

Frame E

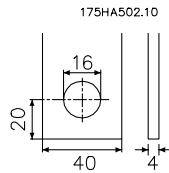

Frame F

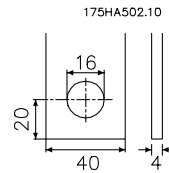

Frame G

■ Operation on different mains type

Mains type		Operation of the filter module
TN	Directly grounded star point	Allowed
TN	Indirectly grounded star point	Allowed
IT	Isolated star point	Allowed

The filter module has been designed completely symmetrically for three phase operation and without reference to the star point or protective earth.

■ Typical installation in a panel or other enclosures

To avoid high frequency noise coupling keep a minimum distance of 150 mm to:

- a) mains/supply wires
- b) motor wires of frequency converter
- c) control- and signal wires (voltage range < 48 V)

To obtain low resistive HF-connections, grounding, screening and other metallic connections (e. g. mounting plates, mounted units) should have a surface as large as possible to metallic ground. Use grounding and potential equalisation wires

with a cross section as large as possible (min. 10mm²) or thick grounding tapes.

Use copper or tinned copper screened wires only, as steel screened wires are not suitable for high frequency applications. Connect the screen with metal clamps or metal glands to the equalisation bars or PE-connections.

Inductive switching units (relay, magnetic contactor etc.) must always be equipped with varistors, RC-circuits or suppressor diodes.

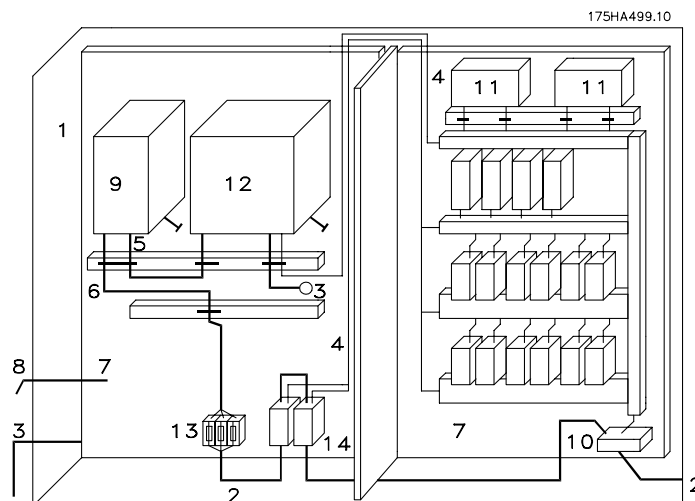

1. Panel
2. Mains supply wire
3. Motor wiring
4. Control wiring
5. Wiring between harmonic filter and frequency converter
6. Mains supply wire of filter module
7. Mounting plate (common star point)
8. Potential equalisation
9. Filter module AHF 0xx
10. Mains connection
11. PLC
12. Frequency converter
13. Mains fuses
14. Mains circuit breaker

■ **Commissioning**



Prior to initial switch-on of the filter module check the wiring for completeness, short-circuit and earth fault.



If the wiring is not correct, a non-intended operation of controller and/or filter module is possible.

First powering up

1. Switch on mains supply :
 - The filter module is ready for operation at once.
2. Check the readiness of the frequency converter:
 - Proceed in accordance with the operating instructions of the frequency converter.

■ 1. General

During operation, filter modules unit may have, according to their type of protection, live, bare, in some cases also movable or rotating parts as well as hot surfaces.

Non - authorized removal of required cover, inappropriate use, incorrect installation or operation, creates the risk of severe injury to persons or damage to material assets.

Further information can be obtained from the documentation.

All operations concerning transport, installation and commissioning as well as maintenance must be carried out by qualified, skilled personnel (IEC 364 and CENELEC HD 384 or DIN VDE 0100 and IEC-Report 664 or DIN VDE 0110 and national regulations for the preventions of accidents must be observed).

According to this basic safety information qualified skilled personnel are persons who are familiar with the erection, assembly, commissioning and operation of the product and who have the qualifications necessary for their occupation .

■ 2. Application as directed

Filter modules are components, which are designed for installation in electrical systems or machinery. When installing in machines, commissioning of the filter modules (i.e. the starting of operation as directed) is prohibited until it is proven, that the machine corresponds to the regulations of the EC Directive 83/392/EEC (Machinery Directive); EN 60204 must be observed.

Commissioning (i.e. starting operation as directed) is only allowed when there is compliance with the EMC-Directive 89/336/EEC.

The filter modules meet the requirements of the Low-Voltage Directive 73/23/EEC. The technical data and information on the connection conditions must be obtained from the nameplate and the documentation and must be observed in all cases.

■ 3. Transport, Storage

Notes on transport, storage and appropriate handling must be observed.

The filter modules have to be protected from inadmissible stress. In particular during transport and handling no components are allowed to be bend

and / or isolating distances may not be altered.

The units are equipped with electrostatic sensitive devices, which may be damaged by improper handling. Therefore it has to be avoided to get in contact with electronic components. If electronic components are damaged mechanically the unit must not be put into operation, as it cannot be ensured, that all relevant standards are observed. Climatic conditions must be observed according to prEN 50178.

■ 4. Installation

The devices must be erected and cooled according to the regulations of the corresponding documentation.

The filter modules must be protected from inappropriate loads. Particularly during transport and handling, components must not be bent and / or isolating distances must not be changed. Touching of electronic components and contacts must be avoided.

Filter modules contain electro-statically sensitive components, which can easily be damaged by inappropriate handling. Electrical components must not be damaged or destroyed mechanically (health risk are possible!).

■ 5. Electrical Installation

When working on live filter modules, the valid national regulations for the prevention of accidents (e.g. VBG 4) must be observed. Before any installation or connection works, the pant has to be switched off and to be secured properly.

The electrical installation must be carried out according to the appropriate regulations (e.g. cable cross-sections, fuses, PE-connection). More detailed information is included in the documentation. When using the filter module with frequency converters without safe separation from the supply line (to VDE 0100) all control wiring has to be included in further protective measures (e.g. double insulated or shielded, grounded and insulated).

■ 6. Operation

Systems where filter modules are installed, if applicable, have to be equipped with additional monitoring and protective devices according to the valid safety regulations e.g. law on technical tools, regulations for the prevention of accidents, etc.

After disconnecting the filter module from the supply voltage, live parts of the filter module and power connections must not be touched immediately, because of possibly charged capacitors.

During operation, all covers and doors must be closed.

■ 7. Maintenance and service

The manufacturer's documentation must be observed.

This safety information must be kept!

The product-specific safety and application notes in these Operating Instructions must also be observed!
